



20AW Commercial Heat Pump



Introduction

Nyle Thermal 20AW is an Air to Water source heat pump, capable of averaging 20 kilowatts of heating capacity.

Standard Features

- Low GWP Refrigerant for SNAP Compliance
- Integral Circulator with improved performance to simplify piping
- Power Monitoring for Compressor Protection
- Build America Buy America compliant
- Monobloc design for easy installation
- High efficiency, warm climate, air-source heat pump
- Industry leading factory support and order lead times
- Active defrost and two stages of onboard freeze protection

Base Model Configurations

✓	Configuration
	Single-Pass Temperature Control OR Multi-Pass Temperature Control
	Axial (Ductless) OR Blower (Ducted) Fan
	208-230v Power OR 460v Power

Available Options

✓	Option	Description
	Add Active Defrost/CWP	Extends Envelope to 35 Degree Fahrenheit Ambient, increases defrosting capabilities
	Add BMS Gateway	Single heat pump communication gateway to building management systems
	Add Stacking Frame	Frame to allow a second heat pump to mount directly above another
	Add Master Control Panel	Provides staging control for multiple heat pumps/tanks. Can take a BMS Gateway
	Add International Crating	Required for cross-border shipments
	Add Factory Startup	Provides for a factory technician to perform the initial on-site startup process
	Remove Integral Circulator	For systems with pressure requirements between 150-250 PSI
	5 Year Compressor Warranty	Extends standard one year warranty to 5 years

Note: All Tolerances +/- 1/8"

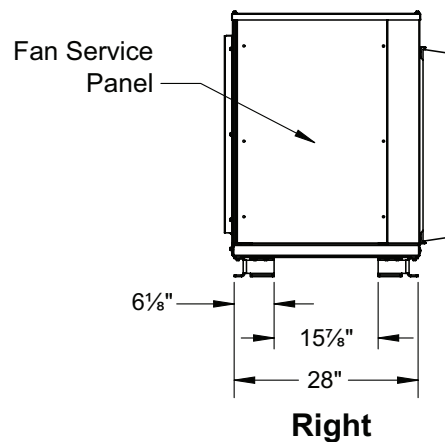
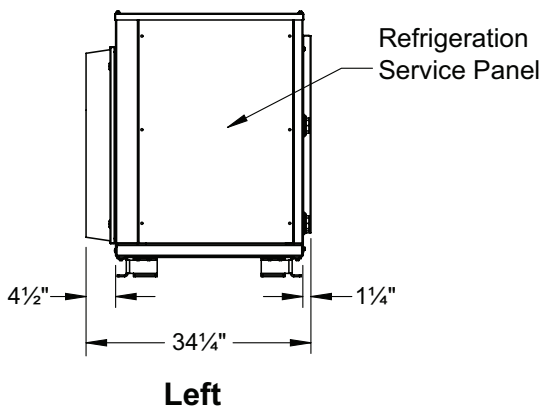
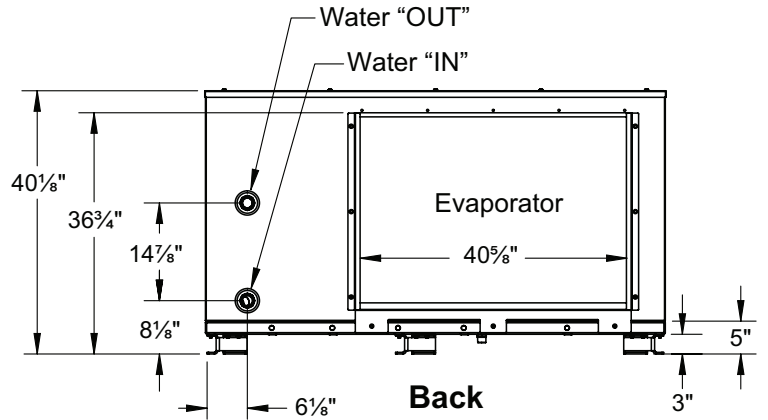
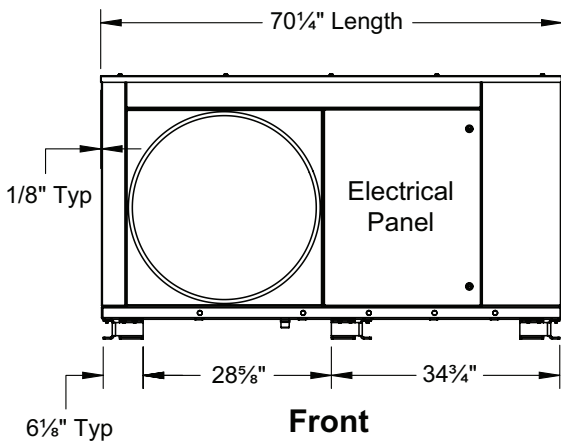
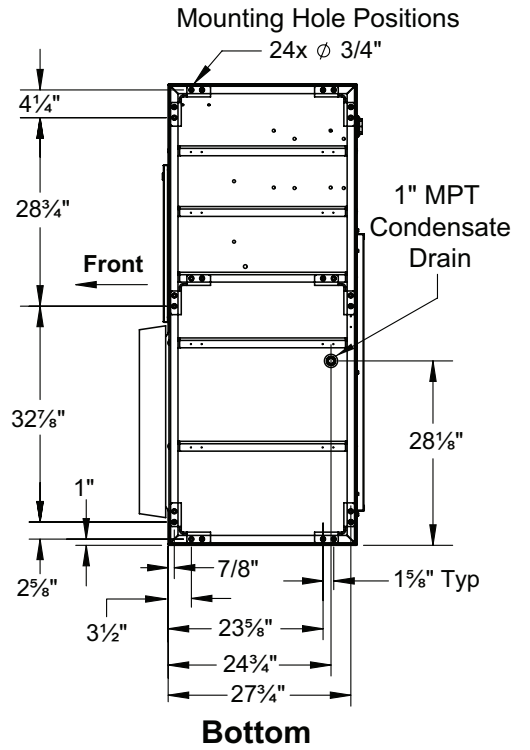
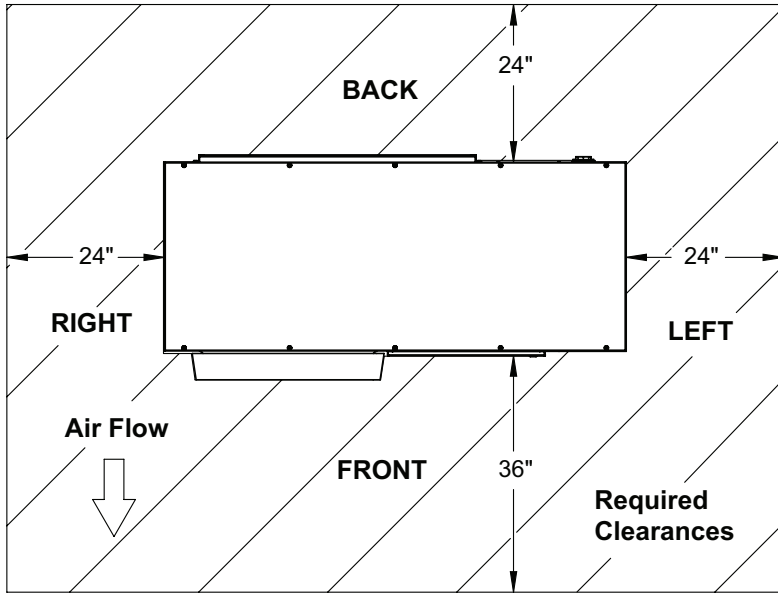

Note: All Tolerances +/- 1/8"

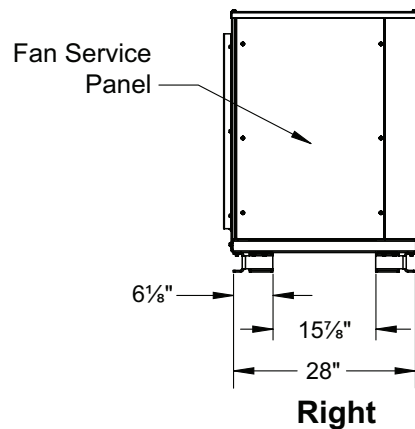
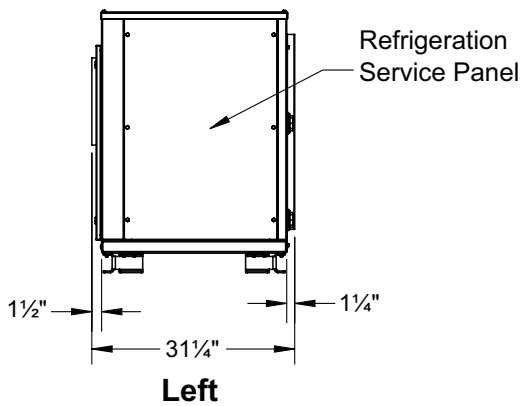
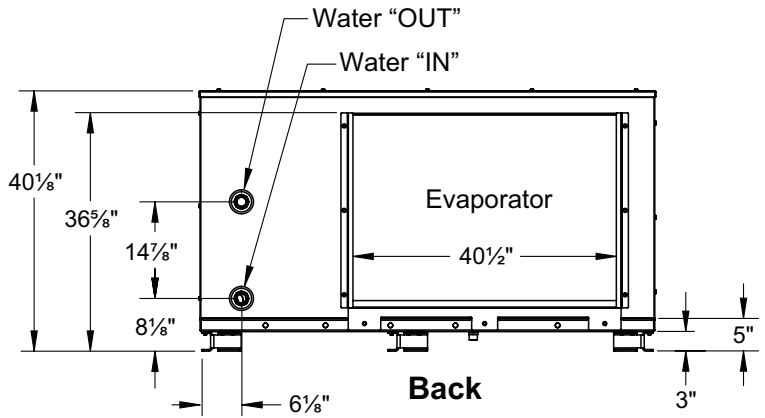
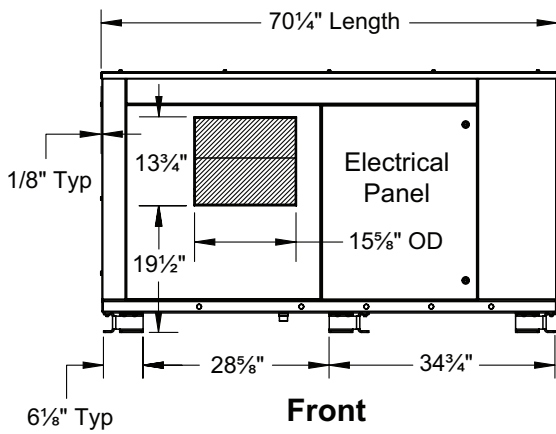
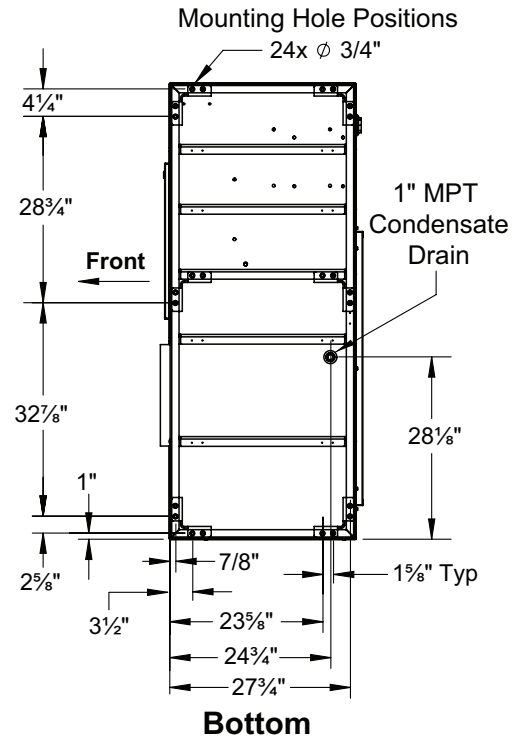
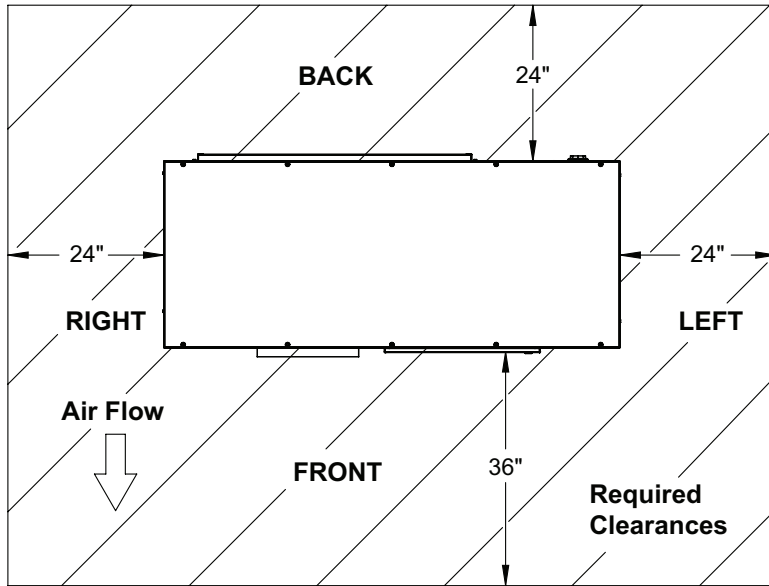

Unit Specifications		Single Pass		Multi Pass	
Water Connections		1" FPT Copper		1½" FPT Copper	
Design Water Flow Rate		9 GPM		20 GPM	
Water Circuit Pressure Drop ⁴		5.9 ft hd		12.5 ft hd	
External Head Pressure Allowed by Unit ⁵		11.6 ft hd		12.5 ft hd	
Recovery Rate ¹		133 Gal/hr			
Compressor Type		Scroll			
Refrigerant		R513a			
Factory Charge		21 lbs.			
Max Water Temp		158°F			
Max Working Pressure ²		150/250 psig			
Ambient Operating Range		Standard: 40° - 120°F			
		CWP: 35° - 120°F			
Minimum Ambient Exposure		Standard: 33°F			
		CWP: -13°F			
Dimensions		70¼" L x 32¾" W x 40¼" H			
Air Flow Rate		2,800 CFM			
Standard Sound Rating ³		87 dB Axial / 76 dB Blower			
External Static Pressure for Ducting		1.5 in wcg (Blower Only)			
Weight		Dry 750 lbs. / Operating 775 lbs.			
Electrical Specifications		Axial Fan		Blower Fan	
Voltage		208-230/3/60	460/3/60	208-230/3/60	460/3/60
Wire and Disconnect Sizing	MCA	50	25	52	27
	MOCP	84	42	87	44
Running Load Amps (RLA)		37.1	18.8	39.7	20.1
Internal Component Data					
Compressor Horsepower (HP)		10		10	
Compressor Locked Rotor Amps (LRA)		239	125	239	125

Notes:

Certified to UL1995/CSA C22.2-2015 on Certificate LC15843-1.

¹ Water heated from 50°F to 150°F with 75°F entering air temperature and 60% relative humidity.

² 150 psi on dhw side with integrated pump, 250 psi on dhw side with integrated pump removed.

³ Sound Pressure recorded 3' from unit face, 3' from ground.

⁴ Pressure drop for external pump applications at design flow rate.

⁵ Pressure drop allowed by integral circulator for external piping.

Entering Air Condition	Air Cooling Capacity (Btu/hr)	Entering Water Temp (°F)	Leaving Water Temp (°F)	Supply Heating Capacity (Btu/hr)	Axial Unit				Blower Unit			
					Power Input (kW)	Heating COP	Cooling COP	Combined COP	Power Input (kW)	Heating COP	Cooling COP	Combined COP
40°F 60% RH	60200	50	57	73700	3.50	6.2	5.0	11.2	4.58	4.7	3.9	8.6
	57000	60	67	71600	4.00	5.2	4.2	9.4	5.08	4.1	3.3	7.4
	54500	70	77	70000	4.40	4.7	3.6	8.3	5.48	3.7	2.9	6.7
	51500	80	87	69200	4.80	4.2	3.1	7.4	5.88	3.4	2.6	6.0
	49100	90	97	68300	5.40	3.7	2.7	6.4	6.48	3.1	2.2	5.3
	47600	100	107	67900	5.95	3.3	2.3	5.7	7.03	2.8	2.0	4.8
	44300	110	117	67500	6.55	3.0	2.0	5.0	7.63	2.6	1.7	4.3
	42100	120	127	67100	7.00	2.8	1.8	4.6	8.08	2.4	1.5	4.0
	40800	130	137	66500	7.40	2.6	1.6	4.2	8.48	2.3	1.4	3.7
38500	140	147	65400	7.90	2.4	1.4	3.9	8.98	2.1	1.3	3.4	
50°F 60% RH	67900	50	58	83500	3.80	6.4	5.2	11.7	4.88	5.0	4.1	9.1
	66500	60	68	82200	4.30	5.6	4.5	10.1	5.38	4.5	3.6	8.1
	64000	70	78	80900	4.67	5.1	4.0	9.1	5.75	4.1	3.3	7.4
	61500	80	88	79900	5.10	4.6	3.5	8.1	6.18	3.8	2.9	6.7
	59000	90	98	79100	5.60	4.1	3.1	7.2	6.68	3.5	2.6	6.1
	56000	100	108	78000	6.15	3.7	2.7	6.4	7.23	3.2	2.3	5.4
	53000	110	118	77200	7.94	2.8	2.0	4.8	9.02	2.5	1.7	4.2
	49800	120	128	76700	7.55	3.0	1.9	4.9	8.63	2.6	1.7	4.3
	48500	130	138	71900	7.95	2.7	1.8	4.4	9.03	2.3	1.6	3.9
47200	140	148	70400	8.40	2.5	1.6	4.1	9.48	2.2	1.5	3.6	
60°F 60% RH	81900	50	59	97800	4.20	6.8	5.7	12.5	5.28	5.4	4.5	10.0
	79500	60	69	96200	4.60	6.1	5.1	11.2	5.68	5.0	4.1	9.1
	76500	70	79	95000	5.00	5.6	4.5	10.1	6.08	4.6	3.7	8.3
	74000	80	89	93400	5.40	5.1	4.0	9.1	6.48	4.2	3.3	7.6
	70500	90	99	92100	5.90	4.6	3.5	8.1	6.98	3.9	3.0	6.8
	66000	100	109	90700	6.50	4.1	3.0	7.1	7.58	3.5	2.6	6.1
	62500	110	119	89400	7.15	3.7	2.6	6.2	8.23	3.2	2.2	5.4
	59000	120	129	88000	7.90	3.3	2.2	5.5	8.98	2.9	1.9	4.8
	57100	130	139	87100	8.20	3.1	2.0	5.2	9.28	2.8	1.8	4.6
55400	140	149	85900	8.60	2.9	1.9	4.8	9.68	2.6	1.7	4.3	
70°F 60% RH	95000	50	60	112500	4.50	7.3	6.2	13.5	5.58	5.9	5.0	10.9
	91500	60	70	110900	4.96	6.6	5.4	12.0	6.04	5.4	4.4	9.8
	87500	70	80	108100	5.30	6.0	4.8	10.8	6.38	5.0	4.0	9.0
	83500	80	90	105600	5.70	5.4	4.3	9.7	6.78	4.6	3.6	8.2
	80000	90	100	104200	6.20	4.9	3.8	8.7	7.28	4.2	3.2	7.4
	76000	100	110	102200	6.80	4.4	3.3	7.7	7.88	3.8	2.8	6.6
	71500	110	120	99900	7.45	3.9	2.8	6.7	8.53	3.4	2.5	5.9
	68000	120	130	98500	8.20	3.5	2.4	6.0	9.28	3.1	2.1	5.3
	65400	130	140	96700	8.90	3.2	2.2	5.3	9.98	2.8	1.9	4.8
61800	140	150	95000	9.40	3.0	1.9	4.9	10.48	2.7	1.7	4.4	
80°F 60% RH	111000	50	62	129500	4.80	7.9	6.8	14.7	5.88	6.5	5.5	12.0
	107000	60	72	128600	5.10	7.4	6.1	13.5	6.18	6.1	5.1	11.2
	104000	70	82	126600	5.75	6.5	5.3	11.8	6.83	5.4	4.5	9.9
	99500	80	92	124000	6.15	5.9	4.7	10.7	7.23	5.0	4.0	9.1
	95000	90	102	121200	6.65	5.3	4.2	9.5	7.73	4.6	3.6	8.2
	90500	100	111	118600	7.20	4.8	3.7	8.5	8.28	4.2	3.2	7.4
	87000	110	121	115800	7.80	4.4	3.3	7.6	8.88	3.8	2.9	6.7
	82000	120	131	113500	8.65	3.8	2.8	6.6	9.73	3.4	2.5	5.9
	79500	130	141	111400	9.10	3.6	2.6	6.1	10.18	3.2	2.3	5.5
74900	140	151	109500	9.70	3.3	2.3	5.6	10.78	3.0	2.0	5.0	
90°F 60% RH	130000	50	63	152100	5.10	8.7	7.5	16.2	6.18	7.2	6.2	13.4
	126700	60	73	148400	5.70	7.6	6.5	14.1	6.78	6.4	5.5	11.9
	122000	70	83	145100	6.20	6.9	5.8	12.6	7.28	5.8	4.9	10.8
	118000	80	93	142300	6.55	6.4	5.3	11.6	7.63	5.5	4.5	10.0
	112000	90	103	137900	7.00	5.8	4.7	10.5	8.08	5.0	4.1	9.1
	109500	100	113	135200	7.40	5.4	4.3	9.7	8.48	4.7	3.8	8.5
	105400	110	122	132900	7.90	4.9	3.9	8.8	8.98	4.3	3.4	7.8
	101900	120	132	129500	8.60	4.4	3.5	7.9	9.68	3.9	3.1	7.0
	99400	130	142	126000	9.50	3.9	3.1	7.0	10.58	3.5	2.8	6.2
95800	140	152	123900	10.20	3.6	2.8	6.3	11.28	3.2	2.5	5.7	

Performance Charts

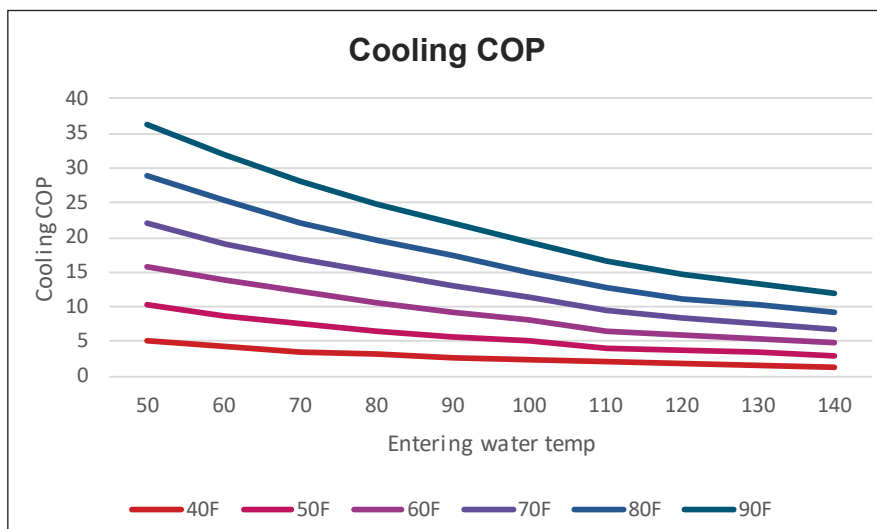
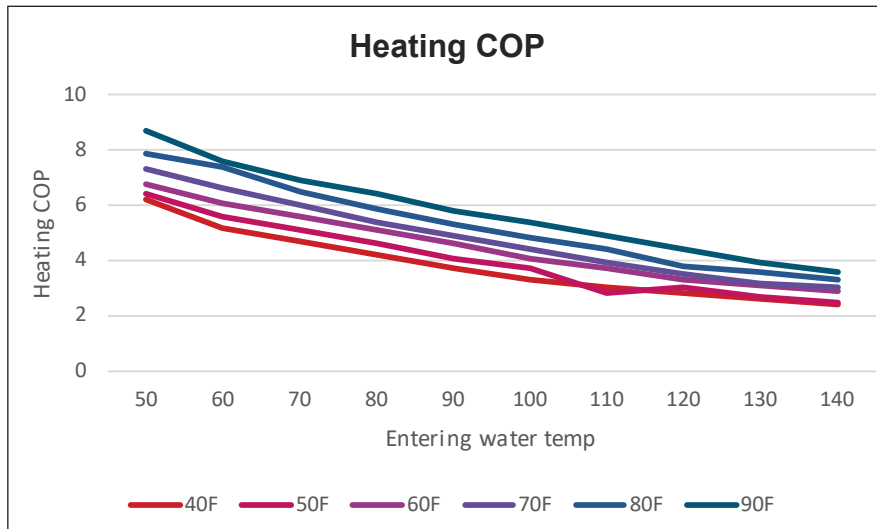
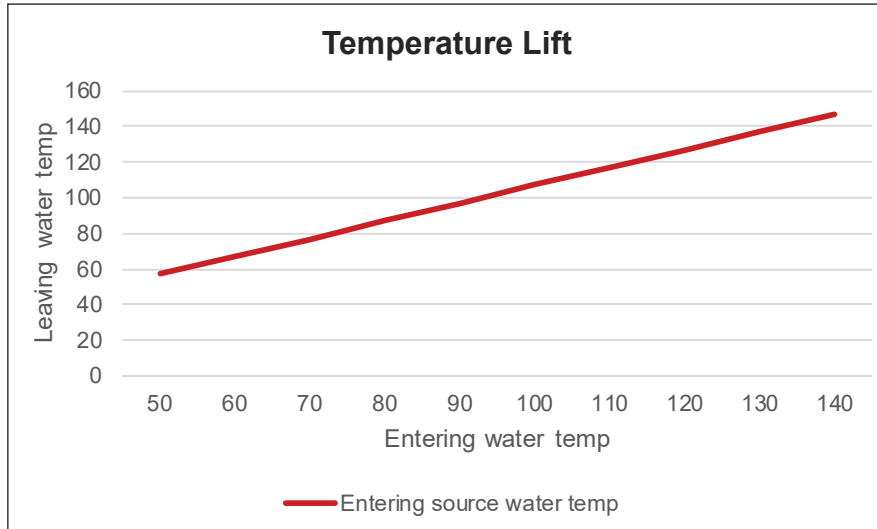



55AW Commercial Heat Pump



Introduction

Nyle Thermal 55AW is an Air to Water source heat pump, capable of averaging 55 kilowatts of heating capacity

Standard Features

- Low GWP Refrigerant for SNAP Compliance
- Integral Circulator with improved performance to simplify piping
- Build America Buy America compliant
- Active Defrost/CWP - extends envelope to 35 degree fahrenheit ambient, increases defrosting capabilities
- Monobloc design for easy installation
- High efficiency, warm climate, air-source heat pump
- Industry leading factory support and order lead times
- Active defrost and two stages of onboard freeze protection

Base Model Configurations

✓	Configuration
	Single-Pass Temperature Control OR Multi-Pass Temperature Control
	Axial (Ductless) OR Blower (Ducted) Fan
	208-230v Power OR 460v Power

Available Options

✓	Option	Description
	Add BMS Gateway	Single heat pump communication gateway to building management systems
	Add Stacking Frame	Frame to allow a second heat pump to mount directly above another
	Add Master Control Panel	Provides staging control for multiple heat pumps/tanks. Can take a BMS Gateway
	Add International Crating	Required for cross-border shipments
	Add Factory Startup	Provides for a factory technician to perform the initial on-site startup process
	Remove Integral Circulator	For systems with pressure requirements between 150-250 PSI
	5 Year Compressor Warranty	Extends standard one year warranty to 5 years

Note: All Tolerances +/- 1/8"

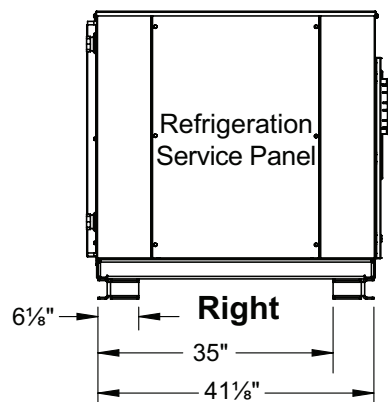
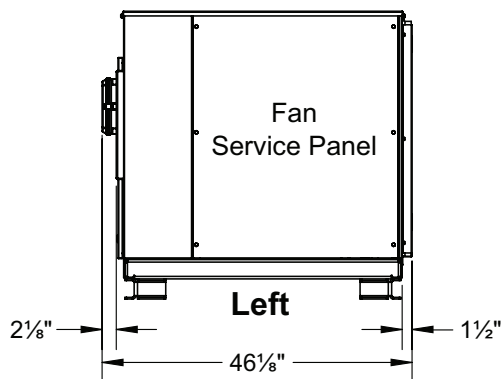
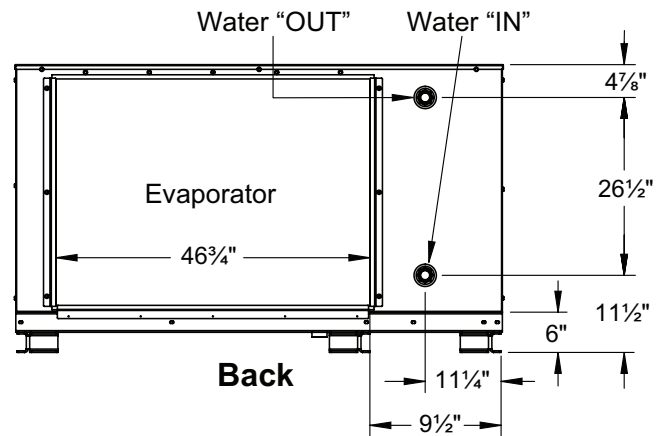
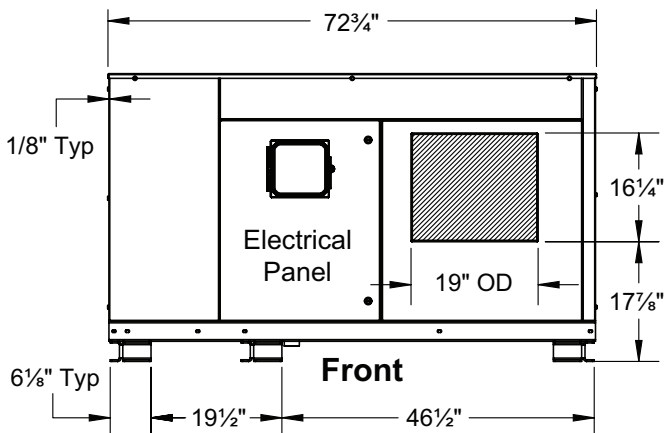
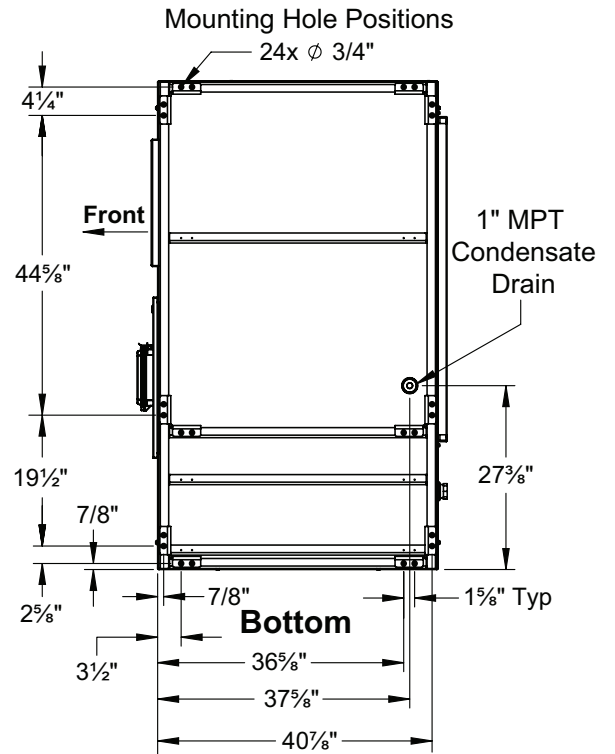
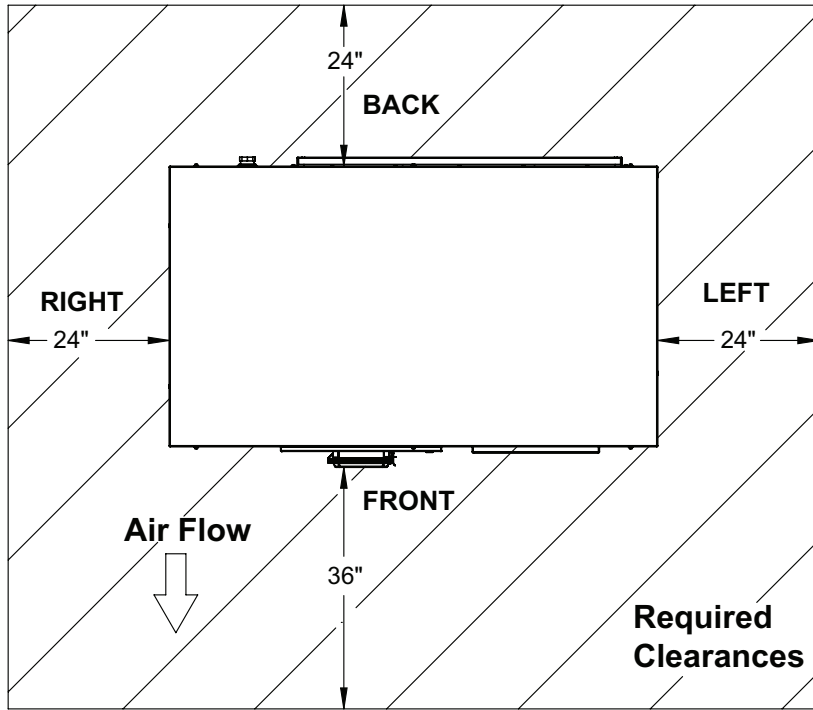

Unit Specifications		Single Pass		Multi Pass	
Water Connections		1½" FPT Copper		2" FPT Copper	
Design Water Flow Rate		18.5 GPM		33 GPM	
Water Circuit Pressure Drop ⁴		7.7 ft hd		12.1 ft hd	
External Head Pressure Allowed by Unit ⁵		16.0 ft hd		10.0 ft hd	
Recovery Rate ¹		270 Gal/hr			
Compressor Type		Scroll			
Refrigerant		R513a			
Factory Charge		30 lbs.			
Max Water Temp		160°F			
Max Working Pressure ²		150/250 psig			
Ambient Operating Range		35° - 120°F			
Minimum Ambient Exposure		-13°F			
Dimensions		72¾" L x 45¼" W x 43" H			
Air Flow Rate		4,500 CFM			
Standard Sound Rating ³		93 dB Axial / 79.9 dB Blower			
External Static Pressure for Ducting		1.2 in wcg (Blower Only)			
Weight		Dry 1,350 lbs. / Operating 1,410 lbs.			
Electrical Specifications		Axial Fan		Blower Fan	
Voltage		208-230/3/60	460/3/60	208-230/3/60	460/3/60
Wire and Disconnect Sizing	MCA	98	41	104	44
	MOCP	170	70	176	73
Running Load Amps (RLA)		76.1	31.6	81.5	34.3
Internal Component Data					
Heating Element FLA		18.1	9.1	18.1	9.1
Compressor Horsepower (HP)		20		20	
Compressor Locked Rotor Amps (LRA)		505	225	505	225

Notes:

Certified to UL1995/CSA C22.2-2015 on Certificate LC15843-1.

- ¹ Water heated from 50°F to 150°F with 75°F entering air temperature and 60% relative humidity.
- ² 150 psi on dhw side with integrated pump, 250 psi on dhw side with integrated pump removed.
- ³ Sound Pressure recorded 3' from unit face, 3' from ground Single point electric service.
- ⁴ Pressure drop for external pump applications at design flow rate.
- ⁵ Pressure drop allowed by integral circulator for external piping.

Entering Air Condition	Air Cooling Capacity (Btu/hr)	Entering Water Temp (°F)	Leaving Water Temp (°F)	Supply Heating Capacity (Btu/hr)	Axial Unit				Blower Unit			
					Power Input (kW)	Heating COP	Cooling COP	Combined COP	Power Input (kW)	Heating COP	Cooling COP	Combined COP
40°F 60% RH	113200	50	57	142500	8.15	5.1	4.1	9.2	9.79	5.1	4.1	9.2
	112000	60	67	141500	8.35	5.0	3.9	8.9	9.99	5.0	3.9	8.9
	109000	70	77	140500	8.90	4.6	3.6	8.2	10.54	4.6	3.6	8.2
	104000	80	87	139900	9.95	4.1	3.1	7.2	11.59	4.1	3.1	7.2
	99500	90	97	138800	11.10	3.7	2.6	6.3	12.74	3.7	2.6	6.3
	95500	100	107	138300	12.50	3.2	2.2	5.5	14.14	3.2	2.2	5.5
	90000	110	117	137500	13.90	2.9	1.9	4.8	15.54	2.9	1.9	4.8
	86500	120	127	136900	14.50	2.8	1.7	4.5	16.14	2.8	1.7	4.5
	83200	130	137	136400	15.80	2.5	1.5	4.1	17.44	2.5	1.5	4.1
80100	140	147	135800	16.80	2.4	1.4	3.8	18.44	2.4	1.4	3.8	
50°F 60% RH	136600	50	58	165200	8.35	5.8	4.8	10.6	9.99	5.8	4.8	10.6
	132000	60	68	164500	8.50	5.7	4.6	10.2	10.14	5.7	4.6	10.2
	130000	70	78	163200	9.15	5.2	4.2	9.4	10.79	5.2	4.2	9.4
	125000	80	88	161800	10.20	4.6	3.6	8.2	11.84	4.6	3.6	8.2
	119000	90	98	159900	11.40	4.1	3.1	7.2	13.04	4.1	3.1	7.2
	113000	100	108	158300	12.70	3.7	2.6	6.3	14.34	3.7	2.6	6.3
	107000	110	118	158100	14.40	3.2	2.2	5.4	16.04	3.2	2.2	5.4
	100000	120	128	156900	15.50	3.0	1.9	4.9	17.14	3.0	1.9	4.9
	96500	130	138	157000	16.30	2.8	1.7	4.6	17.94	2.8	1.7	4.6
93000	140	148	156200	17.50	2.6	1.6	4.2	19.14	2.6	1.6	4.2	
60°F 60% RH	160000	50	59	190200	8.60	6.5	5.5	11.9	10.24	6.5	5.5	11.9
	156000	60	69	188200	9.00	6.1	5.1	11.2	10.64	6.1	5.1	11.2
	152000	70	79	186400	9.50	5.8	4.7	10.4	11.14	5.8	4.7	10.4
	145000	80	89	184100	10.60	5.1	4.0	9.1	12.24	5.1	4.0	9.1
	140000	90	99	182200	11.80	4.5	3.5	8.0	13.44	4.5	3.5	8.0
	133000	100	109	181000	13.20	4.0	3.0	7.0	14.84	4.0	3.0	7.0
	126000	110	119	178800	14.80	3.5	2.5	6.0	16.44	3.5	2.5	6.0
	119000	120	129	177500	16.70	3.1	2.1	5.2	18.34	3.1	2.1	5.2
	114000	130	139	176800	17.80	2.9	1.9	4.8	19.44	2.9	1.9	4.8
108000	140	149	176100	18.50	2.8	1.7	4.5	20.14	2.8	1.7	4.5	
70°F 60% RH	191000	50	61	220500	8.90	7.3	6.3	13.6	10.54	7.3	6.3	13.6
	186000	60	71	218500	9.20	7.0	5.9	12.9	10.84	7.0	5.9	12.9
	179000	70	81	214700	9.90	6.4	5.3	11.7	11.54	6.4	5.3	11.7
	171000	80	91	211500	11.00	5.6	4.6	10.2	12.64	5.6	4.6	10.2
	164000	90	101	208600	12.20	5.0	3.9	9.0	13.84	5.0	3.9	9.0
	157000	100	110	206400	13.60	4.4	3.4	7.8	15.24	4.4	3.4	7.8
	149000	110	120	203800	15.20	3.9	2.9	6.8	16.84	3.9	2.9	6.8
	142000	120	130	202400	17.00	3.5	2.4	5.9	18.64	3.5	2.4	5.9
	136000	130	140	201500	18.10	3.3	2.2	5.5	19.74	3.3	2.2	5.5
131000	140	150	200100	19.40	3.0	2.0	5.0	21.04	3.0	2.0	5.0	
80°F 60% RH	221500	50	63	258200	9.10	8.3	7.1	15.4	10.74	8.3	7.1	15.4
	216000	60	73	254700	9.50	7.9	6.7	14.5	11.14	7.9	6.7	14.5
	207000	70	82	248500	10.40	7.0	5.8	12.8	12.04	7.0	5.8	12.8
	199000	80	92	245600	11.60	6.2	5.0	11.2	13.24	6.2	5.0	11.2
	194000	90	102	241656	12.80	5.5	4.4	10.0	14.44	5.5	4.4	10.0
	185000	100	112	237800	14.30	4.9	3.8	8.7	15.94	4.9	3.8	8.7
	176000	110	122	234600	16.00	4.3	3.2	7.5	17.64	4.3	3.2	7.5
	167000	120	132	231700	17.80	3.8	2.7	6.6	19.44	3.8	2.7	6.6
	159000	130	141	228500	18.80	3.6	2.5	6.0	20.44	3.6	2.5	6.0
155000	140	151	224900	19.90	3.3	2.3	5.6	21.54	3.3	2.3	5.6	
90°F 60% RH	241000	50	64	275600	9.40	8.6	7.5	16.1	11.04	8.6	7.5	16.1
	234000	60	74	270000	9.70	8.2	7.1	15.2	11.34	8.2	7.1	15.2
	226000	70	83	266500	10.70	7.3	6.2	13.5	12.34	7.3	6.2	13.5
	217000	80	93	261000	11.80	6.5	5.4	11.9	13.44	6.5	5.4	11.9
	208000	90	103	255700	13.10	5.7	4.7	10.4	14.74	5.7	4.7	10.4
	195000	100	113	248400	14.50	5.0	3.9	9.0	16.14	5.0	3.9	9.0
	183000	110	122	241291	16.20	4.4	3.3	7.7	17.84	4.4	3.3	7.7
	170000	120	132	235700	18.10	3.8	2.8	6.6	19.74	3.8	2.8	6.6
	164000	130	142	232500	19.20	3.5	2.5	6.1	20.84	3.5	2.5	6.1
159000	140	151	228600	20.30	3.3	2.3	5.6	21.94	3.3	2.3	5.6	

Performance Charts

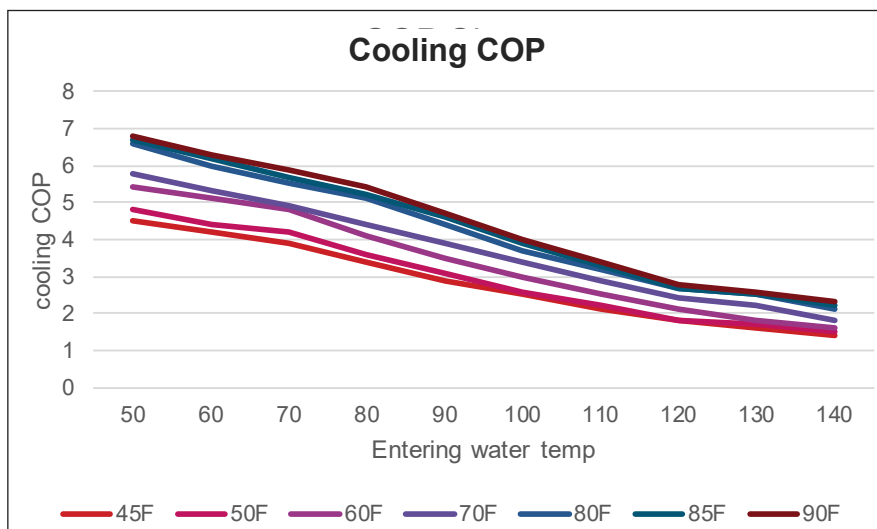
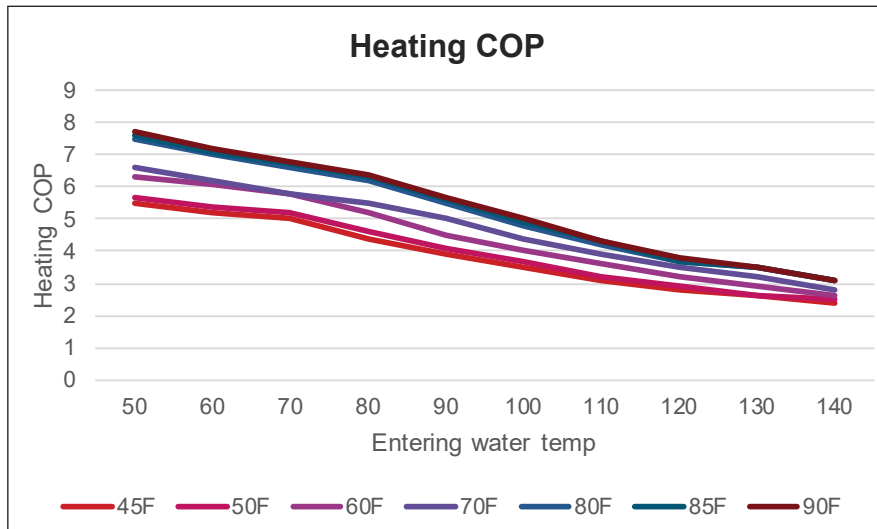
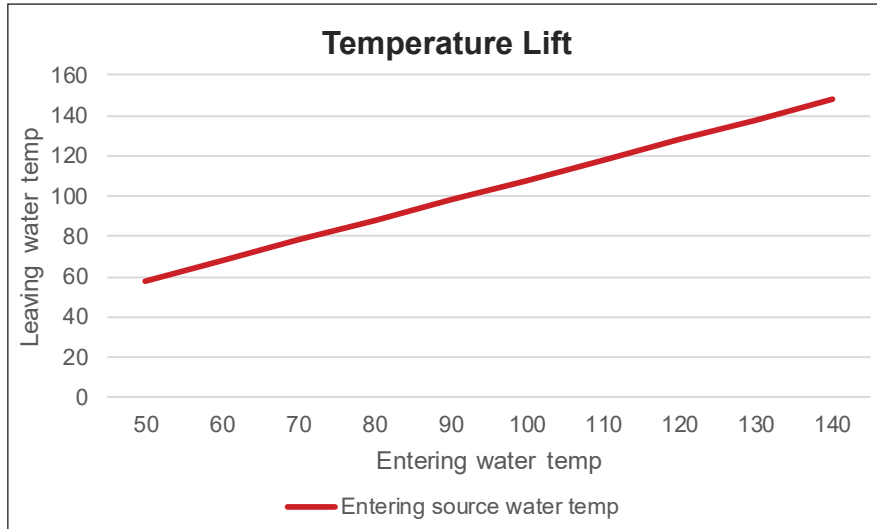



75AW Commercial Heat Pump



Introduction

Nyle Thermal 75AW is an Air to Water source heat pump, capable of averaging 75 kilowatts of heating capacity.

Standard Features

- Low GWP Refrigerant for SNAP Compliance
- Integral Circulator with improved performance to simplify piping
- Power Monitoring for Compressor Protection
- Build America Buy America compliant
- Monobloc design for easy installation
- High efficiency, warm climate, air-source heat pump
- Industry leading factory support and order lead times
- Active defrost and two stages of onboard freeze protection

Base Model Configurations

✓	Configuration
	Single-Pass Temperature Control OR Multi-Pass Temperature Control
	Axial (Ductless) OR Blower (Ducted) Fan
	208-230v Power OR 460v Power

Available Options

✓	Option	Description
	Add BMS Gateway	Single heat pump communication gateway to building management systems
	Add Master Control Panel	Provides staging control for multiple heat pumps/tanks. Can take a BMS Gateway
	Add International Crating	Required for cross-border shipments
	Add Factory Startup	Provides for a factory technician to perform the initial on-site startup process
	Remove Integral Circulator	For systems with pressure requirements between 150-250 PSI
	Add Active Defrost/CWP	Extends Envelope to 35 Deg. F. Ambient, increases defrosting capabilities
	5 Year Compressor Warranty	Extends standard one year warranty to 5 years

Note: All Tolerances +/- 1/8"

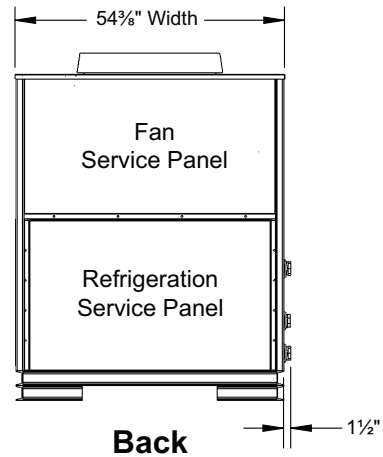
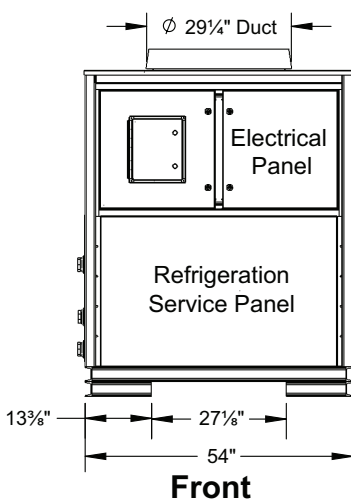
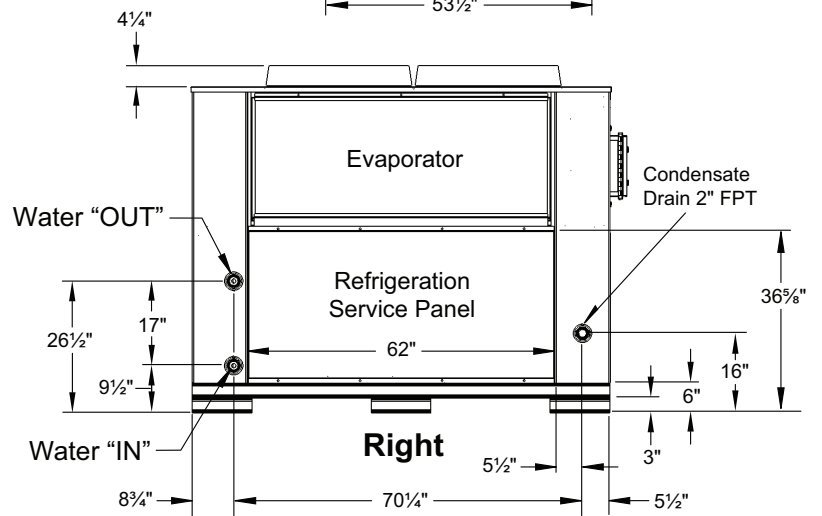
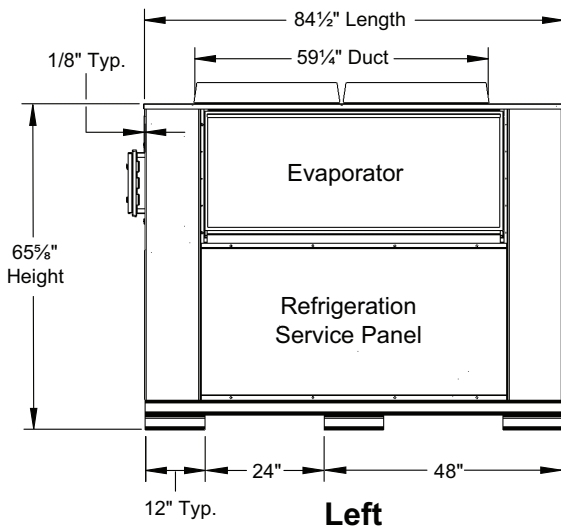
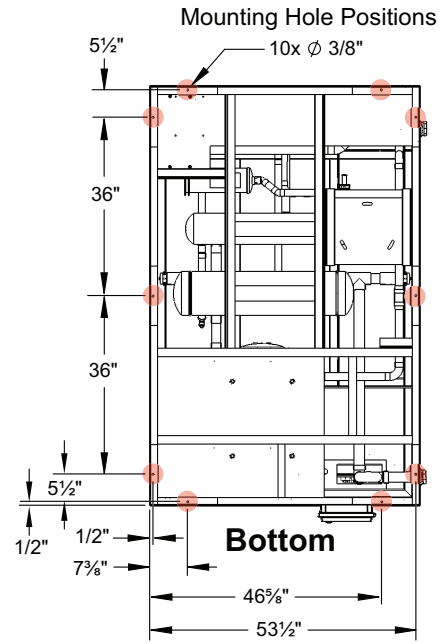
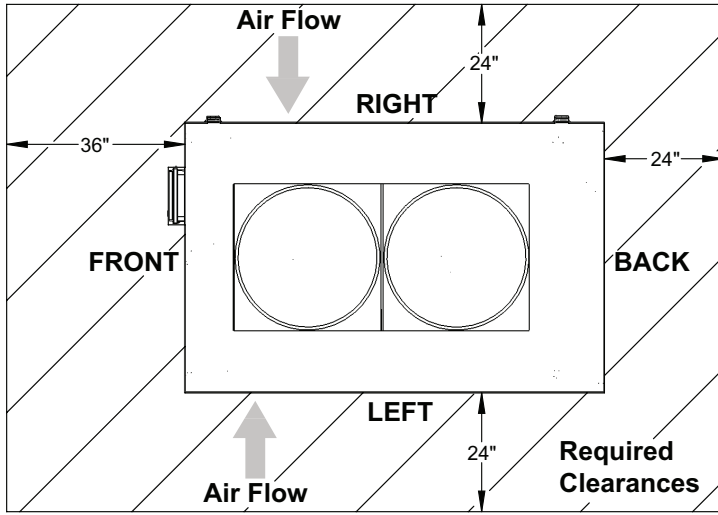

Note: All Tolerances +/- 1/8"

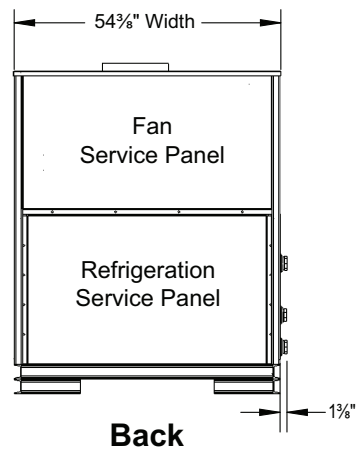
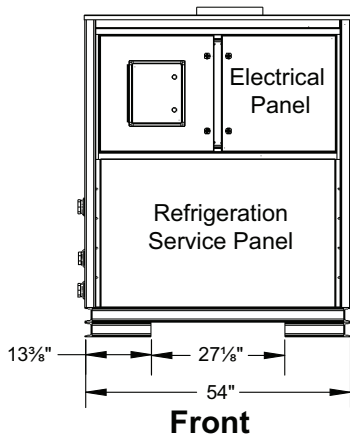
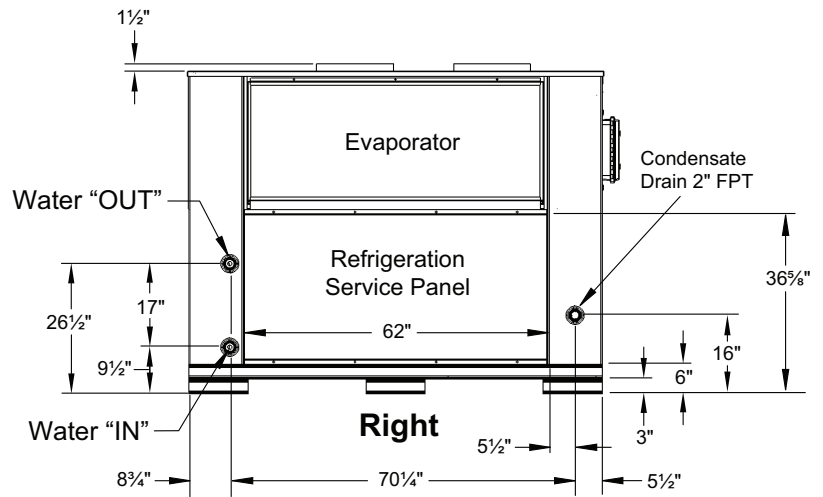
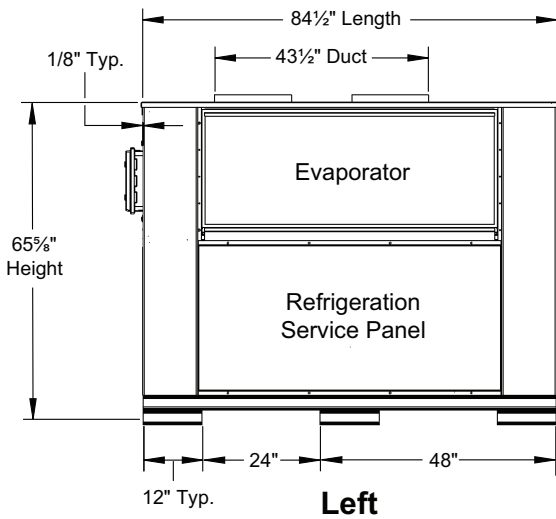
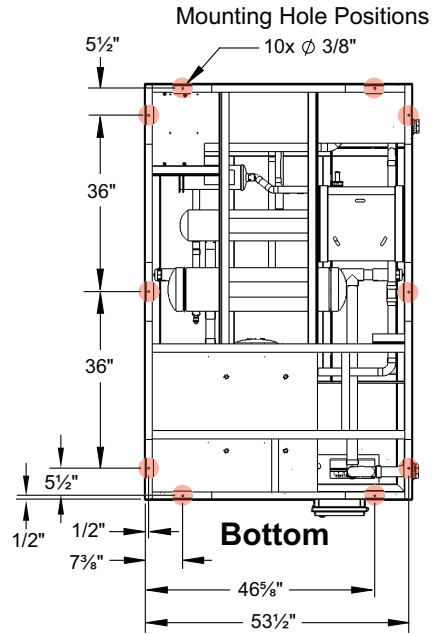
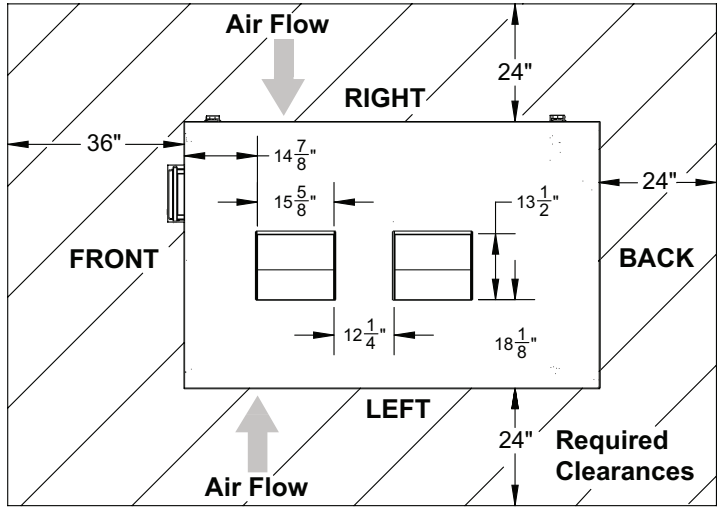

Unit Specifications		Single Pass		Multi Pass	
Water Connections		1½" FPT Copper		2" FPT Copper	
Design Water Flow Rate		25 GPM		33 GPM	
Water Circuit Pressure Drop ⁴		12.2 ft hd		18.9 ft hd	
External Head Pressure Allowed by Unit ⁵		20.3 ft hd		6.1 ft hd	
Recovery Rate ¹		340 Gal/hr			
Compressor Type		Reciprocating			
Refrigerant		R513a			
Factory Charge		42 lbs.			
Max Water Temp		160°F			
Max Working Pressure ²		150/250 psig			
Ambient Operating Range		Standard: 35° - 120°F			
		CWP: 35° - 120°F			
Minimum Ambient Exposure		Standard: 33°F			
		CWP: -13°F			
Dimensions		84½" L x 54¾" W x 70" H			
Air Flow Rate		8,000 CFM			
Standard Sound Rating ³		64 dB Axial / 77.5 dB Blower			
External Static Pressure for Ducting		1.5 in wcg (Blower Only)			
Weight		Dry 2,100 lbs. / Operating 2,175 lbs.			
Electrical Specifications		Axial Fan		Blower Fan	
Voltage		208-230/3/60	460/3/60	208-230/3/60	460/3/60
Wire and Disconnect Sizing	MCA	102	51	111	56
	MOCP	177	88	185	93
Running Load Amps (RLA)		87.9	39.8	87.9	44.1
Internal Component Data					
Heating Element FLA		40.2	22.6	40.2	22.6
Compressor Horsepower (HP)		25		25	
Compressor Locked Rotor Amps (LRA)		262	218	262	218

Notes:

Certified to UL1995/CSA C22.2-2015 on Certificate LC15843-1.

- ¹ Water heated from 50°F to 150°F with 75°F entering air temperature and 60% relative humidity.
- ² 150 psi on dhw side with integrated pump, 250 psi on dhw side with integrated pump removed.
- ³ Sound Pressure recorded 3' from unit face, 3' from ground Single point electric service.
- ⁴ Pressure drop for external pump applications at design flow rate.
- ⁵ Pressure drop allowed by integral circulator for external piping.

Entering Air Condition	Air Cooling Capacity (Btu/hr)	Entering Water Temp (°F)	Leaving Water Temp (°F)	Supply Heating Capacity (Btu/hr)	Axial Unit				Blower Unit			
					Power Input (kW)	Heating COP	Cooling COP	Combined COP	Power Input (kW)	Heating COP	Cooling COP	Combined COP
40°F 60% RH	169300	50	58	202000	13.39	4.4	3.7	8.1	13.39	4.4	3.7	8.1
	152700	60	68	187800	14.06	3.9	3.2	7.1	14.06	3.9	3.2	7.1
	141700	70	77	178900	14.70	3.6	2.8	6.4	14.70	3.6	2.8	6.4
	131300	80	87	170900	15.38	3.3	2.5	5.8	15.38	3.3	2.5	5.8
	122000	90	97	163600	16.14	3.0	2.2	5.2	16.14	3.0	2.2	5.2
	112400	100	106	155400	16.41	2.8	2.0	4.8	16.41	2.8	2.0	4.8
	105800	110	116	150500	16.48	2.7	1.9	4.6	16.48	2.7	1.9	4.6
	89700	120	125	133700	16.68	2.3	1.6	3.9	16.68	2.3	1.6	3.9
	76300	130	135	120600	16.78	2.1	1.3	3.4	16.78	2.1	1.3	3.4
69100	140	145	113000	16.79	2.0	1.2	3.2	16.79	2.0	1.2	3.2	
50°F 60% RH	196200	50	59	231500	13.97	4.9	4.1	9.0	13.97	4.9	4.1	9.0
	185600	60	69	223400	14.87	4.4	3.7	8.1	14.87	4.4	3.7	8.1
	172800	70	79	213700	16.01	3.9	3.2	7.1	16.01	3.9	3.2	7.1
	163400	80	88	207000	16.59	3.7	2.9	6.5	16.59	3.7	2.9	6.5
	152300	90	98	199300	17.65	3.3	2.5	5.8	17.65	3.3	2.5	5.8
	134200	100	108	183600	17.88	3.0	2.2	5.2	17.88	3.0	2.2	5.2
	127000	110	117	177600	18.64	2.8	2.0	4.8	18.64	2.8	2.0	4.8
	113600	120	127	165100	18.89	2.6	1.8	4.3	18.89	2.6	1.8	4.3
	93900	130	136	145600	18.94	2.3	1.5	3.7	18.94	2.3	1.5	3.7
88100	140	146	139400	18.99	2.2	1.4	3.5	18.99	2.2	1.4	3.5	
60°F 60% RH	234400	50	61	270800	14.44	5.5	4.8	10.3	14.44	5.5	4.8	10.3
	218400	60	70	258300	15.59	4.9	4.1	9.0	15.59	4.9	4.1	9.0
	207000	70	80	250300	16.49	4.4	3.7	8.1	16.49	4.4	3.7	8.1
	191500	80	100	239400	17.80	3.9	3.2	7.1	17.80	3.9	3.2	7.1
	188000	90	109	230100	18.82	3.6	2.9	6.5	18.82	3.6	2.9	6.5
	169200	100	107	223200	19.62	3.3	2.5	5.9	19.62	3.3	2.5	5.9
	154700	110	119	211200	20.34	3.0	2.2	5.3	20.34	3.0	2.2	5.3
	133000	120	128	197300	21.18	2.7	1.8	4.6	21.18	2.7	1.8	4.6
	120300	130	137	181300	21.5	2.5	1.6	4.1	21.5	2.5	1.6	4.1
108300	140	147	168400	21.7	2.3	1.5	3.7	21.7	2.3	1.5	3.7	
70°F 60% RH	275900	50	63	313600	14.83	6.2	5.5	11.7	14.83	6.2	5.5	11.7
	262000	60	72	303700	16.00	5.6	4.8	10.4	16.00	5.6	4.8	10.4
	247800	70	82	294200	17.38	5.0	4.2	9.1	17.38	5.0	4.2	9.1
	234400	80	92	285600	18.78	4.5	3.7	8.1	18.78	4.5	3.7	8.1
	220100	90	101	275900	20.15	4.0	3.2	7.2	20.15	4.0	3.2	7.2
	205800	100	111	265600	21.29	3.7	2.8	6.5	21.29	3.7	2.8	6.5
	185800	110	120	249300	22.40	3.3	2.4	5.7	22.40	3.3	2.4	5.7
	168600	120	130	235900	23.52	2.9	2.1	5.0	23.52	2.9	2.1	5.0
	152200	130	140	221500	24.14	2.7	1.8	4.5	24.14	2.7	1.8	4.5
138500	140	149	209100	24.39	2.5	1.7	4.2	24.39	2.5	1.7	4.2	
80°F 60% RH	326200	50	65	364100	14.34	7.4	6.7	14.1	14.34	7.4	6.7	14.1
	307400	60	74	352800	16.49	6.3	5.5	11.7	16.49	6.3	5.5	11.7
	294100	70	84	343200	18.18	5.5	4.7	10.3	18.18	5.5	4.7	10.3
	278700	80	93	333700	19.90	4.9	4.1	9.0	19.90	4.9	4.1	9.0
	264200	90	103	324500	21.44	4.4	3.6	8.0	21.44	4.4	3.6	8.0
	243900	100	113	310500	23.06	3.9	3.1	7.0	23.06	3.9	3.1	7.0
	223600	110	122	294000	24.41	3.5	2.7	6.2	24.41	3.5	2.7	6.2
	197700	120	131	272200	25.60	3.1	2.3	5.4	25.60	3.1	2.3	5.4
	185500	130	140	261600	25.86	3.0	2.1	5.1	25.86	3.0	2.1	5.1
165300	140	150	238500	26.18	2.7	1.9	4.5	26.18	2.7	1.9	4.5	
90°F 60% RH	338500	50	67	385100	13.69	8.2	7.2	15.5	13.69	8.2	7.2	15.5
	324200	60	76	369000	15.49	7.0	6.1	13.1	15.49	7.0	6.1	13.1
	308500	70	85	354800	17.47	6.0	5.2	11.1	17.47	6.0	5.2	11.1
	280100	80	95	341100	19.44	5.1	4.2	9.4	19.44	5.1	4.2	9.4
	260950	90	104	320500	21.33	4.4	3.6	8.0	21.33	4.4	3.6	8.0
	231500	100	113	306500	23.07	3.9	2.9	6.8	23.07	3.9	2.9	6.8
	208900	110	122	295300	24.57	3.5	2.5	6.0	24.57	3.5	2.5	6.0
	197700	120	131	272000	25.77	3.1	2.2	5.3	25.77	3.1	2.2	5.3
	185500	130	140	261200	26.24	2.9	2.1	5.0	26.24	2.9	2.1	5.0
165300	140	150	248500	26.66	2.7	1.8	4.5	26.66	2.7	1.8	4.5	

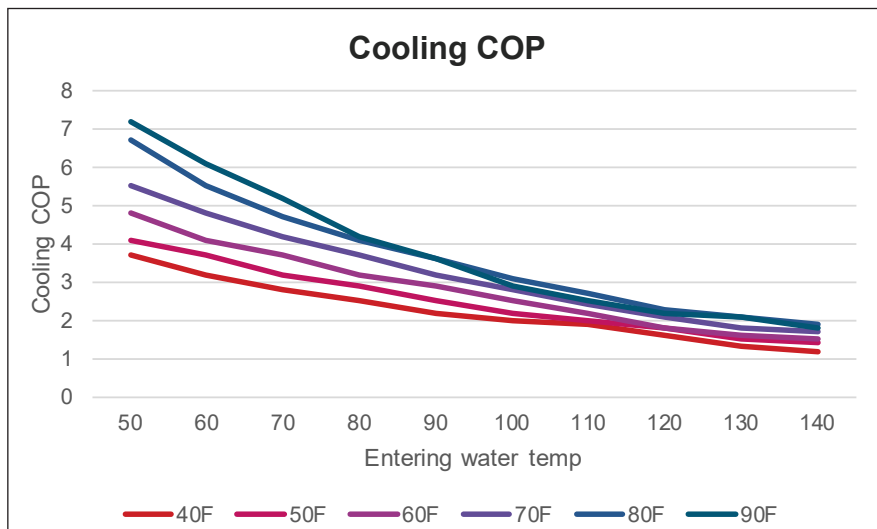
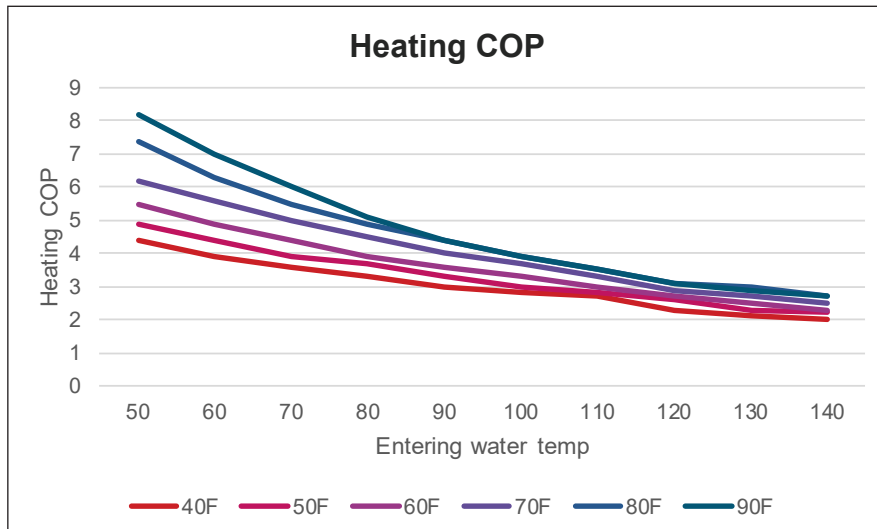
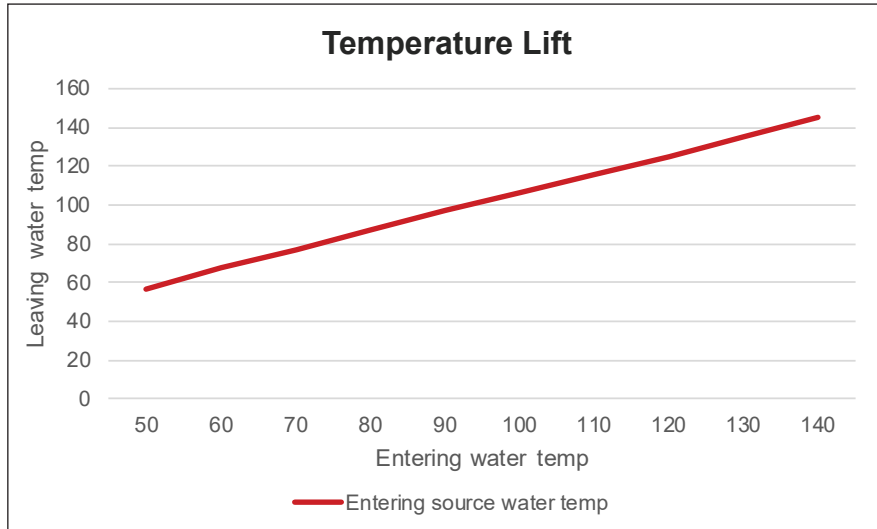



100AW Commercial Heat Pump



Introduction

Nyle Thermal 100AW is an Air to Water source heat pump, capable of averaging 100 kilowatts of heating capacity

Standard Features

- Low GWP Refrigerant for SNAP Compliance
- Integral Circulator and ECM Fans
- Build America Buy America compliant
- Monobloc design for easy installation
- High efficiency, cold climate, air-source heat pump
- Industry leading factory support and order lead times
- Active defrost and two stages of onboard freeze protection
- Dual power feed for easy generator backup of freeze protection functions
- Fully Ductable on intake and discharge sides

Base Model Configurations

✓	Configuration
	Single-Pass Temperature Control
	ECM Blower (Ducted/Ductless)
	208-230v Power OR
	460v Power

Available Options

✓	Option	Description
	Add BMS Gateway	Single heat pump communication gateway to building management systems
	Add Master Control Panel	Provides staging control for multiple heat pumps/tanks. Can take a BMS Gateway
	Add International Crating	Required for cross-border shipments
	Add Factory Startup	Provides for a factory technician to perform the initial on-site startup process
	Add Ductless Cowl	Covers discharge fans for protection in ductless applications
	Add Remote Outdoor Sensor	Allows outdoor temperature sensing for interior ducted applications
	Add Unified Power Package	Eliminate dual power feed for a single point power configuration
	Service Part Kit	See SPK Submittal for details/options.
	5 Year Compressor Warranty	Extends standard one year warranty to 5 years

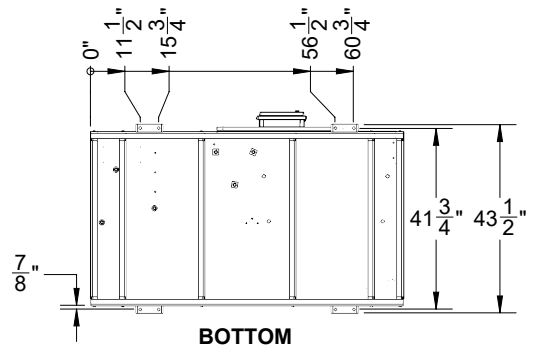
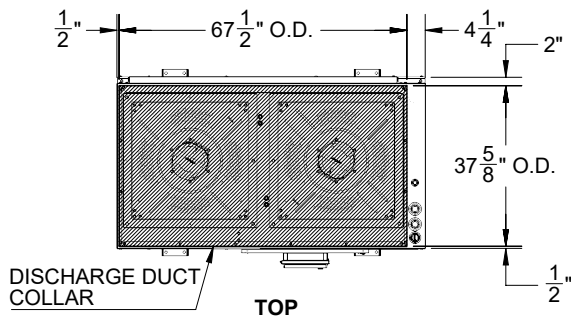
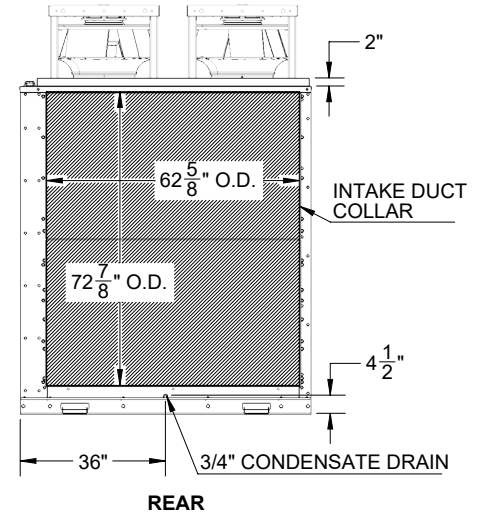
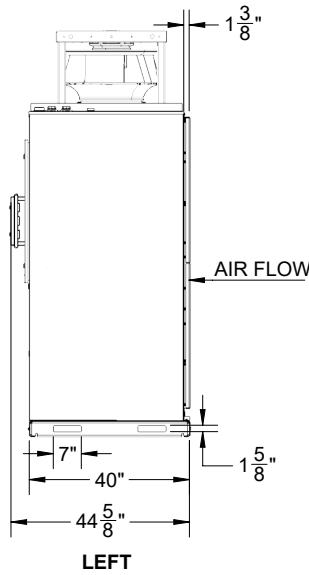
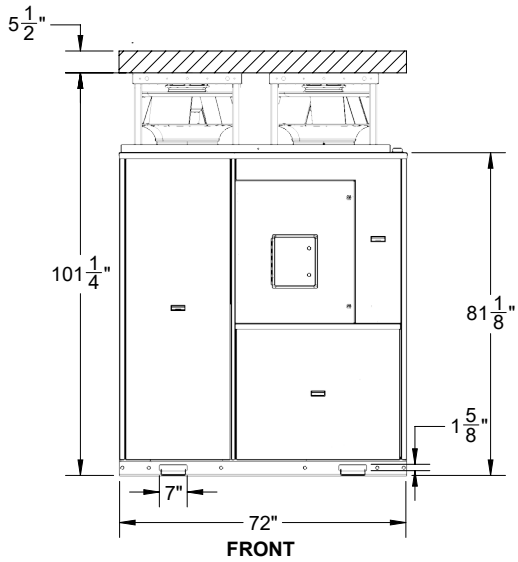
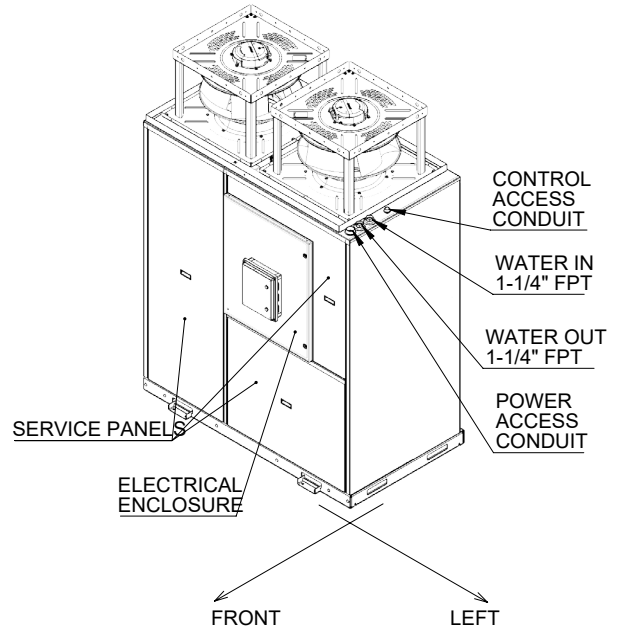
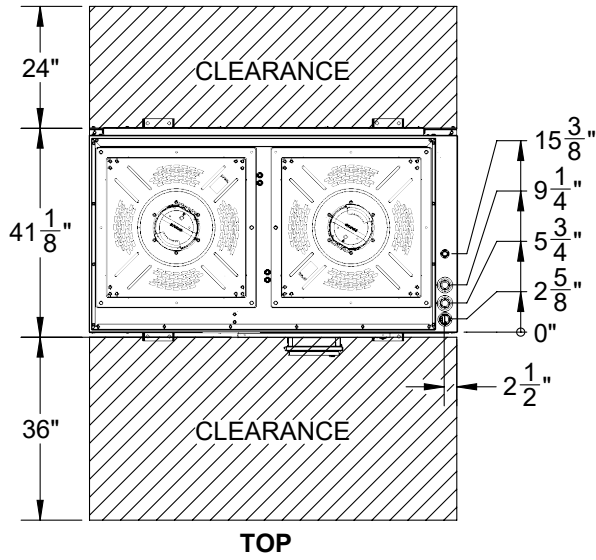

Unit Specifications		Single Pass			
Water Connections		1¼" FPT Copper			
Design Water Flow Rate		16 GPM			
External Head Pressure Allowed by Unit ³		14.0 ft hd			
Recovery Rate ¹		405 Gal/hr			
Compressor Type		Reciprocating			
Refrigerant		R513A			
Factory Charge		60 lbs.			
Max Water Temp		160°F			
Max Working Pressure		150 psig			
Ambient Operating Range		Standard: 10° - 120°F			
Minimum Ambient Exposure		-15°F			
Dimensions		40" L x 72" W x 101¼" H			
Air Flow Rate		16,000 CFM			
Standard Sound Rating ²		78 dBA Max. Standard / 73.3 dBA Max. Quiet Mode.			
External Static Pressure for Ducting		1.5 in wcg (Blower Only)			
Weight		Dry 2,300 lbs. / Operating 2,400 lbs.			
Electrical Specifications		100AW – Standard Power Package		100AW – Unified Power Package	
Voltage		208-230/3/60	460/3/60	208-230/3/60	460/3/60
Wire and Disconnect Sizing	MCA	123	63	129	66
	MOCP	222	113	228	116
Running Load Amps (RLA)		110	57	110	57
Power Factor		0.86		0.86	
Short Circuit Current Rating (SCCR)		100		100	
Internal Component Data					
Fan Motor Full Load Amps FLA		40.2	22.6	40.2	22.6
Fan Horsepower (HP)		5.1	6.02	5.1	6.02
Compressor Horsepower (HP)		30		30	
Compressor Locked Rotor Amps (LRA)		294	245	294	245
Internal Pump Full Load Amps (FLA)		On Back-up Feed		2.1	
Backup Circuit Single Phase Power Feed		120/1/60			
Min. Circuit Ampacity (MCA)		14	14		
Full Load Amps (FLA)		11.3	11.1		
Max. Overcurrent Protection (MOCP)		25	20		
Internal Pump Full Load Amps (FLA)		2.1	2.1		
Circuit Power		1360	1330		
Short Circuit Current Rating (SCCR)		100			

Notes:

¹ Water heated from 50°F to 150°F with 75°F entering air temperature and 60% relative humidity.

² Sound Pressure recorded 3' from unit face, 3' from ground Single point electric service.

³ Pressure drop allowed by integral circulator for external piping.

140° F Leaving Water Temperature (LWT)										
H2O inlet temperature 40°F										
Ambient DB °F	10	24	30	40	50	60	70	80	90	100
Heating capacity (kbtu/h)	98	126	141	171	205	241	287	333	351	351
Cooling capacity (kbtu/h)	60	76	88	112	140	171	211	252	269	269
Unit heating COP	2.4	2.4	2.5	2.8	3.0	3.2	3.4	3.6	3.8	3.9
H2O flow rate (gpm)	2.0	2.5	2.8	3.4	4.1	4.8	5.7	6.6	7.0	7.0
H2O inlet temperature 50°F										
Ambient DB °F	10	24	30	40	50	60	70	80	90	100
Heating capacity (kbtu/h)	98	126	141	171	205	241	287	333	351	351
Cooling capacity (kbtu/h)	60	76	88	112	140	171	211	252	269	269
Unit heating COP	2.4	2.4	2.5	2.8	3.0	3.2	3.4	3.6	3.8	3.9
H2O flow rate (gpm)	2.2	2.8	3.1	3.8	4.5	5.3	6.4	7.4	7.8	7.8
H2O inlet temperature 60°F										
Ambient DB °F	10	24	30	40	50	60	70	80	90	100
Heating capacity (kbtu/h)	98	126	141	171	205	241	287	333	351	351
Cooling capacity (kbtu/h)	60	76	88	112	140	171	211	252	269	269
Unit heating COP	2.4	2.4	2.5	2.8	3.0	3.2	3.4	3.6	3.8	3.9
H2O flow rate (gpm)	2.4	3.1	3.5	4.3	5.1	6.0	7.2	8.3	8.8	8.8
H2O inlet temperature 70°F										
Ambient DB °F	10	24	30	40	50	60	70	80	90	100
Heating capacity (kbtu/h)	98	126	141	171	205	241	287	333	351	351
Cooling capacity (kbtu/h)	60	76	88	112	140	171	211	252	269	269
Unit heating COP	2.4	2.4	2.5	2.8	3.0	3.2	3.4	3.6	3.8	3.9
H2O flow rate (gpm)	2.8	3.6	4.0	4.9	5.8	6.9	8.2	9.5	10.0	10.0

Note: All conditions are at 50% relative humidity.

120° F Leaving Water Temperature (LWT)										
H2O inlet temperature 40°F										
Ambient DB °F	10	24	30	40	50	60	70	80	90	100
Heating capacity (kbtu/h)	106	139	156	187	233	264	308	351	398	398
Cooling capacity (kbtu/h)	68	93	107	133	165	202	242	282	327	327
Unit heating COP	2.6	2.9	3.0	3.3	3.8	3.9	4.1	4.4	4.9	5.0
H2O flow rate (gpm)	2.7	3.5	3.9	4.7	5.8	6.6	7.7	8.8	9.9	9.9
H2O inlet temperature 50 °F										
Ambient DB °F	10	24	30	40	50	60	70	80	90	100
Heating capacity (kbtu/h)	106	139	156	187	233	264	308	351	398	398
Cooling capacity (kbtu/h)	68	93	107	133	165	202	242	282	327	327
Unit heating COP	2.6	2.9	3.0	3.3	3.8	3.9	4.1	4.4	4.9	5.0
H2O flow rate (gpm)	3.0	4.0	4.4	5.3	6.6	7.5	8.8	10.0	11.3	11.3
H2O inlet temperature 60°F										
Ambient DB °F	10	24	30	40	50	60	70	80	90	100
Heating capacity (kbtu/h)	106	139	156	187	233	264	308	351	398	398
Cooling capacity (kbtu/h)	68	93	107	133	165	202	242	282	327	327
Unit heating COP	2.6	2.9	3.0	3.3	3.8	3.9	4.1	4.4	4.9	5.0
H2O flow rate (gpm)	3.5	4.6	5.2	6.2	7.7	8.8	10.2	11.7	13.2	13.2
H2O inlet temperature 70°F										
Ambient DB °F	10	24	30	40	50	60	70	80	90	100
Heating capacity (kbtu/h)	106	139	156	187	233	264	308	351	398	398
Cooling capacity (kbtu/h)	68	93	107	133	165	202	242	282	327	327
Unit heating COP	2.6	2.9	3.0	3.3	3.8	3.9	4.1	4.4	4.9	5.0
H2O flow rate (gpm)	4.2	5.5	6.2	7.4	9.3	10.5	12.3	14.0	15.9	15.9

Note: All conditions are at 50% relative humidity.